

序號Serial No. 2024052301F

日期Date: 2024-05-23

致TO:

產品ITEM: 石英晶体谐振器

客户物料编码Customer P/N: 01020306040

供应商编码Supplier P/N: T2327687319

规格型号SPECIFICATION: TDXLF-206/32.768KHZ/±20ppm/12.5pf/40KΩ

請收到我們的規格書後，簽字回傳。
Please confirm you received this specification, sign and fax it to us.

接收確認RECEIVING CONFIRMATION	
日期DATA	
接收RECEIVED	

擬制Prepared by: 应金会

批准Confirmed by: 王琴飞

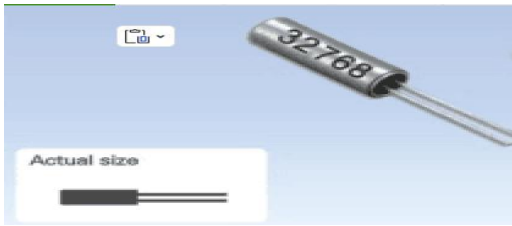

Features 特性

- Frequency Range: 32.768KHz 頻率範圍: 32.768KHz
- Best suited for portable devices with low current consumption 非常適合低功耗的便攜設備
- For a clock source in digital equipments 適用於數碼設備的所有時鐘源

STANDARD SPECIFICATIONS 標準規格

Frequency Range	頻率範圍	32.768KHz	Need to specify
Load Capacitance	負載電容	12.5pF	Need to specify
Drive Level	激勵電平	1.0μW Max	
Frequency Tolerance	調整頻差	±20ppm	at 25°C Need to specify
Series Resistance	諧振電阻	40Kohm Max	at 25°C Depend on frequency
Turnover Temperature	拐點溫度	25±5°C	
Temperature Coefficient	二次溫度係數	$[-0.034 \pm 0.006] \text{ppm}/^\circ\text{C}^2$	
Operating Temperature Range	工作溫度範圍	-20~+70°C	
Storage Temperature Range	保存溫度範圍	-40~+85°C	
Motional Capacitance	動態電容	0.003pF Typical	和頻率有關 Depend on frequency
Shunt Capacitance	靜態電容	1.35pF Typical	和頻率有關 Depend on frequency
Capacitance Ratio	C0/C1	500 Typical	和頻率有關 Depend on frequency
Aging[first year]	第一年老化率	±3ppm Max	25°C ±3°C
Quality Factor	Q值	50000 Typical	和頻率有關 Depend on frequency
Insulation Resistance	絕緣阻抗	500Mohm Min.	DC100V±15V(Pin to Pin, Pin to case)

OUTLINE DIMENSIONS

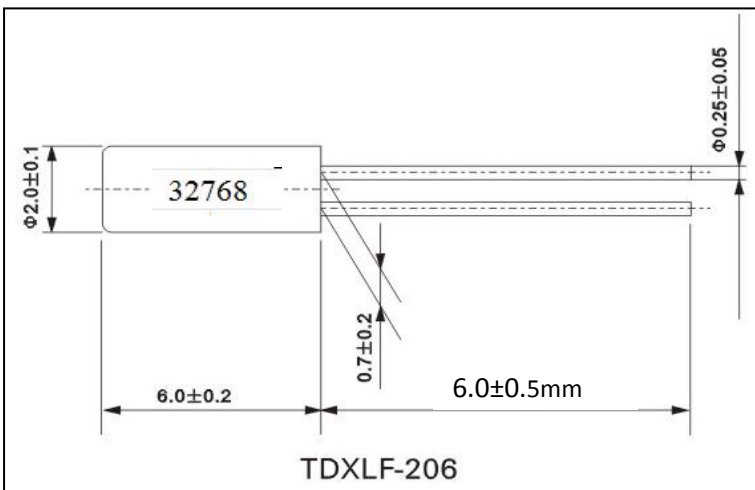

FREQUENCY VS. TEMPERATURE CURVE

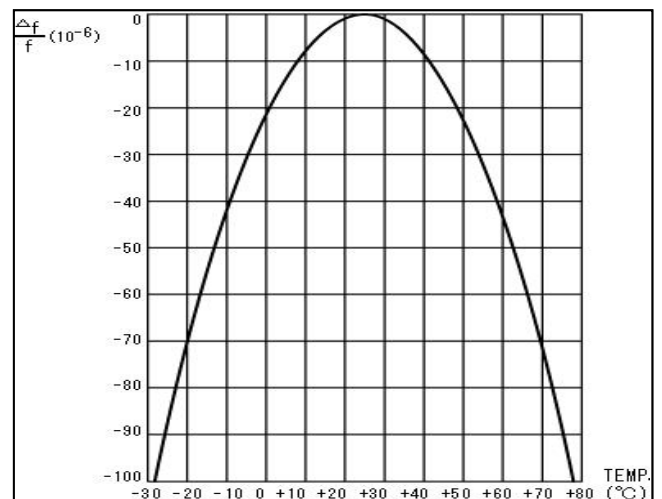

外壳不能接地使用

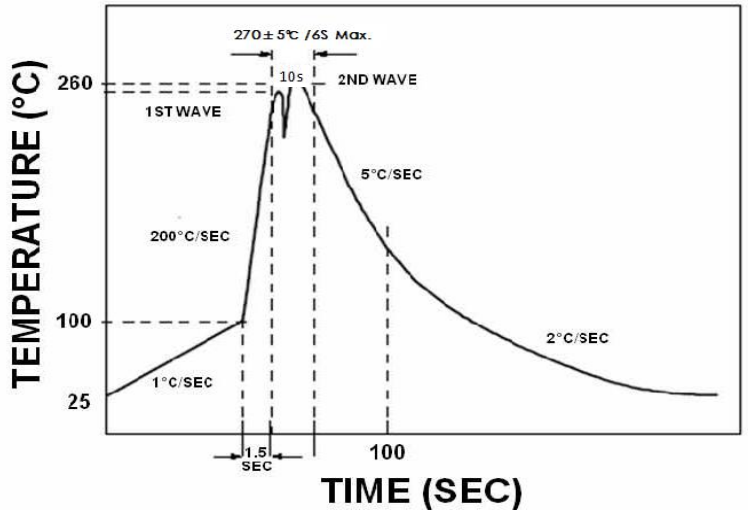
No.	Test Items	Test Method and Condition	Requirements
1	振動 Vibration	(1)振動頻率Vibration Frequency 10 to 55Hz (2)振動幅度Vibration Amplitude 1.5mm (3)周期 Cycle Time 1-2min(10-55-10Hz) (4)振動方向Direction X.Y.Z (5)振動時間Duration 2h/each direction	頻率變化最大:±10ppm Frequency Change:±10ppm Max. 電阻變化最大:5kohm Resistance Change:5kohm Max.
2	衝擊 Shock	從75cm高的地方自由跌落3次到30mm厚的硬木板上 3 Times free drop from 75cm height to hard wooden board of thickness more than 30mm	頻率變化最大:±10ppm Frequency Change:±10ppm Max. 電阻變化最大:5kohm Resistance Change: 5kohm Max.
3	氣密性 Leakage	晶體放入氦加壓罐內，充入氦氣壓力0.5-0.6Mpa保持1小時；然後使用氦質譜檢漏儀測試。 Put crystal units into a hermetic container and Helium for 0.5-0.6 Mpa,and keep it for 1h;Check the leakage by a Helium leak detector	漏氣率小於:1x10 ⁻⁸ mbar.l/s Leakage:1x10 ⁻⁸ mbar.l/s Max.
4	可焊性 Solderability	將引線浸入完全熔化的焊錫鍋內3-5s，焊錫溫度245°C±5°C Put the leads of crystal units into solder melted tank for 3 to 5s Temperature of solder melted tank is 245°C±5°C	浸過引線面積的95%以上被新焊錫覆蓋 The dipped surface of the leads should be at least 95% covered with continuous new solder coating
5	手工焊接耐熱 Soldering iron resistance	350°C±10°C,3+1/-0 sec	頻率變化最大:±10ppm Frequency Change:±10ppm Max. 電阻變化最大:10kohm Resistance Change: 10kohm Max.
6	波峰焊耐熱 Wave soldering resistance	<p>推荐使用下面的波峰焊溫度曲線進行波峰焊接。 The WAVE SOLDERING PROFILE as below is recommended:</p> 	

No.	Test Items	Test Method and Condition	Requirements
7	引線強度(引線直插式晶體) Lead Strength(DIP)	用0.9kg(9N)的力持續拉晶體引線30s±5s; 用0.45kg的力折引線成90°2次(折彎處離機體1.5mm以上) ; The crystal lead with the 0.9kg(9N)power(keep it for 30s±5s) and bend the crystal lead 90° with 0.45kg power and two times (which you want to bend should be more than 1.5mm from the case)	引線無異常 The crystal lead is not abnormality
8	耐高溫能力 High Temperature Endurance	晶體放置於85°C±2°C環境中2小時後，常溫放置1-2小時 The crystal units shall be put in somewhere for 2 hours at temperature of 85°C±2°C,then keep it for 1 to 2 hours under room temperature	頻率變化最大:±10ppm Frequency Change:±10ppm Max. 電阻變化最大:5kohm Resistance Change:5kohm Max.
9	耐低溫能力 Low Temperature Endurance	晶體放置於-25°C環境中2小時後，常溫放置1-2小時 The crystal units shall be put in somewhere for 2 hours at temperature of -25°C,then keep it for 1 to 2 hours under room temperature	
10	耐濕性 Humidity Endurance	晶體放置於40°C、相對濕度90-95%環境中48小時後，常溫放置1-2小時 The crystal units shall be put in somewhere at 40°C in relative humidity of 90-95% for 48 hours, then keep it for one or two hours under room temperature	
11	高低溫迴圈 Temperature Cycle	溫度從-40°C(保持30分鐘)升高到100°C(保持30分鐘)，再降到-40°C(保持30分鐘)然後回到室溫25°C完成一個迴圈，共計5個迴圈 Temperature shift from low(-40°C) to high(100°C,keep 30 minutes),satisfy high(100°C) to low(-40°C,keep 30 minutes),then go up to room temperature for 5 cycles	

使用說明 Processing Instructions

下面的說明和資訊供用戶正確理解和使用我們公司的石英晶體系列產品，預防不當的加工方式對石英晶體的損壞，確保用戶設備的可靠性

The following instructions and information are provided for the purpose of having the user understand the proper way to process our crystal products to prevent problems prior to use and enhance the reliability of the equipment to which they are applied.

No.	PROCESSING INSTRUCTIONS																								
1	<p>石英晶體意外跌落 When dropped by mistake</p> <p>設計和製造的石英晶體本身具有耐衝擊能力,但是當石英晶體元件經受劇烈的機械衝擊，如跌落到地板上或安裝期間劇烈震動時，在使用之前需要進行電性能確認</p> <p>The crystal units are designed and manufactured to resist physical shocks.However,when the crystal units are subjected to excessive impact such as being dropped onto the floor or giving shocks during processing,need to make sure its satisfactory performance before using it.</p>																								
2	<p>焊接 Soldering</p> <p>(1)使用電烙鐵焊接時，引線應該在4秒內焊接完畢，電烙鐵溫度不能高於350°C</p> <p>Lead wires should be soldered within 4 seconds with the soldering iron heated to a temperature no higher than 350°C</p> <p>(2)使用浸錫方式焊接時，引線應該在10秒內焊接完畢，焊錫溫度不能高於260°C，並且注意不能將整個晶體浸錫.推薦使用垂直安裝方式，避免熱力直接傳導到晶體上</p> <p>In solder-dip processing,the leads should be soldered within 10 seconds with a temperature no higher than 260°C.Mounting in upright is recommendable to prevent the heat conduction directly to the body of the crystal unit.</p> <p>(3)使用波峰焊接時，請參照下面的波峰焊溫度曲線</p> <p>The WAVE SOLDERING PROFILE as below is recommended for TDXMLF-206 tuning fork crystal resonators.</p> <div data-bbox="363 1111 1066 1644" data-label="Figure"><p>The graph illustrates the recommended wave soldering temperature profile for TDXMLF-206 tuning fork crystal resonators. The vertical axis represents Temperature in degrees Celsius (°C), ranging from 25 to 260. The horizontal axis represents Time in seconds (SEC), ranging from 0 to 100. The profile starts at 25°C and rises at 1°C/SEC to 100°C. It then rises at 200°C/SEC to a peak of 270 ± 5°C within 10 seconds. The peak is divided into a 1st wave and a 2nd wave. The temperature then falls at 5°C/SEC to 100°C and finally at 2°C/SEC to 25°C. A 1.5-second dwell time is indicated at the start of the 1st wave.</p><table border="1"><caption>Wave Soldering Profile Data</caption><thead><tr><th>Time (SEC)</th><th>Temperature (°C)</th><th>Rate (°C/SEC)</th><th>Notes</th></tr></thead><tbody><tr><td>0</td><td>25</td><td>-</td><td>Start</td></tr><tr><td>1.5</td><td>100</td><td>1</td><td>1.5 SEC dwell</td></tr><tr><td>10</td><td>270 ± 5</td><td>200</td><td>10s to peak</td></tr><tr><td>100</td><td>100</td><td>5</td><td>5°C/SEC cooling</td></tr><tr><td>100</td><td>25</td><td>2</td><td>2°C/SEC cooling</td></tr></tbody></table></div>	Time (SEC)	Temperature (°C)	Rate (°C/SEC)	Notes	0	25	-	Start	1.5	100	1	1.5 SEC dwell	10	270 ± 5	200	10s to peak	100	100	5	5°C/SEC cooling	100	25	2	2°C/SEC cooling
Time (SEC)	Temperature (°C)	Rate (°C/SEC)	Notes																						
0	25	-	Start																						
1.5	100	1	1.5 SEC dwell																						
10	270 ± 5	200	10s to peak																						
100	100	5	5°C/SEC cooling																						
100	25	2	2°C/SEC cooling																						

使用說明 Processing Instructions

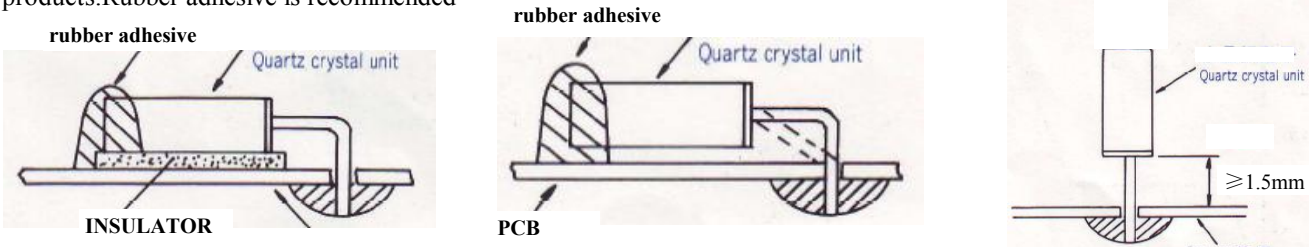
No.	PROCESSING INSTRUCTIONS
3	<p>石英晶體彎腳 TO BEND THE LEAD of cylinder type products</p> <p>(1)當圓柱狀晶體元件需要彎腳時，為了防止彎腳時造成密封玻璃體的破裂，從彎腳處到晶體基座底部距離應大於1.5mm。推薦距離3.0mm,並使用工裝夾具進行彎腳。 When the lead of cylinder type crystal units need to be bent,leave more than 1.5mm (3.0mm is recommendable) of lead from the case in order to prevent from any cracks of the hermetic sealing glass at the root of the lead,and use a jig to bend if possible.</p> <p>(2)當圓柱狀晶體元件進行彎腳時，不要剝離引線的鍍層 When bending the lead of cylinder type crystal units,do not scrape off the soldering plating from the lead surface.</p>
4	<p>元件的安裝 MOUNTING</p> <p>(1)為了避免影響元件電性能或損壞元件，嚴禁將圓柱狀晶體元件外殼焊接在印製板上進行固定。推薦使用橡膠粘結劑進行固定 Soldering the body of the cylinder type crystal units with PCB must be avoided due to deteriorate the characteristics or damage the products. Rubber adhesive is recommended</p> <div data-bbox="145 645 1460 891"></div> <p>(2)當用手工來彎曲引線時，請遵照下列方法 When the lead needs to be bent by hand,please follow the instruction as below: 用手指捏住圓柱晶體的外殼;用鑷子夾住引線要彎曲的部位，該部位離晶體基座底部1.5mm以上（推薦3.0mm）； 用鑷子夾住彎曲引線成90°，不要用力拉引線。用力拉引線可能造成引線根部的玻璃子破裂，而產生漏氣損壞元件電性能。 Hold the body of the cylinder type crystal unit in fingers; Pick at the part with tweezer,which you want to bend. There should be more than 1.5mm(3.0mm is recommended) from the body case; Bend the lead 90° by tweezer without pulling the lead strongly.If pulling the lead strongly may cause any cracks of hermetic sealing glass at the root of the lead and may cause the leakage and the characteristics to deteriorate.</p>
5	<p>石英晶體元件的清洗 CLEANING</p> <p>(1)惡劣的超聲波清洗或超聲波焊接可能會影響和損壞石英晶體元件。如果您對晶體元件進行了超聲波清洗，請一定在使用前確認晶體元件是否受到了影響和損壞 Crystal units may be affected and destroyed at worst by supersonic cleaning or supersonic welding. Please be sure to check if your cleaning and welding process affects any damage to crystal units before using.</p> <p>(2)有些清洗液也可能造成晶體元件的損壞，請在使用清洗液前確認該清洗液是否適用 Some kinds of cleaning fluid may cause any damage to crystal units. Please be sure to check suitability of the cleaning fluid in advance.</p>
6	<p>貯存 STORAGE</p> <p>石英晶體元件長時間貯存在高溫或高濕環境中，可能會影響頻率的穩定性或可焊性。請將晶體元件貯存在正常的溫度和濕度環境中，避免陽光直射和露水凝結，避免貯存6個月以上再使用，拆封後儘快裝配使用。 Storage of crystal units under higher temperature or high humidity for a long term may affect frequency stability or solderability. Please store the crystal units under the normal temperature and humidity without exposing to direct sunlight and dew condensation ,and avoid the storage of crystal units for more than 6 months,and mount them as soon as possible after unpacking.</p>

包装 PACKING

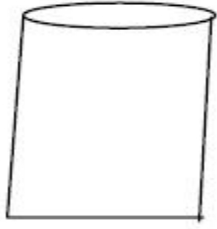

1000pcs/per plastic bag

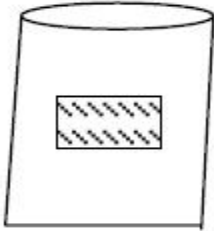

put "accept label" inside



	合格证	
	TYPE	
	FREQUENCY	
	Δ/f ₀	
	CL	
	RES	
	P/N	
	QTY	
	OQC	
	DELIVERY DATE	
	LEAD FREE	



1 inner box=20 bags =20000pcs

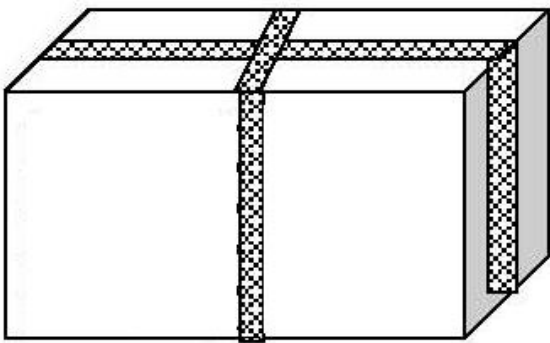

1 carton=10 inner boxes